



ecoGrease-a

high efficiency grease separation
the clear choice for clean water



ecoGrease

“75% of the sewer systems in the United States work at only half capacity because of grease clogs... local governments already spend \$25 billion per year to keep the sewers running.”

The Wall Street Journal - June 4, 2001



Government regulators continue to impose and enforce stricter local and national water-quality regulations. Current grease separation via outside grease trap/grease interceptor systems is inefficient, time consuming and costly.

The ecoGrease Interceptor finally offers the food industry a high efficiency method of controlling the accumulation of grease. The system is easy to use, easy to monitor and will save restaurants, food service providers, food processing facilities AND taxpayers valuable resources.

ecoGrease-a The clear choice for clean water



Designed to exceed removal efficiencies <25ppm!

The ecoGrease system separates liquid, coagulating animal and vegetable fat and grease from water prior to discharge into septic or municipally owned sewers.

For the first time, a grease separation technology will allow the consultant, plumber or end user to not only size the system strictly by flow-rate, but also achieve specific effluent removal efficiencies for these pollutants!

Virtually eliminates grease in sewer systems making this product a **MUST** for institutional kitchens, restaurants and food processing facilities.



Easy to maintain.

The integrated sight glass enables accurate monitoring of accumulated grease levels which determines appropriate disposal intervals.

Easy to clean!

System can be connected to a suction line. Vacuum trucks then simply attach and pump at grade. Saves up to 50% in annual service costs.

Extremely reliable system

uses no external energy supply or electrical parts - only grease resistant HDPE and high grade stainless steel components.



High separation efficiency

designed in accordance with the strict European Standard pr-EN1825 for grease separation.

Installation is simple.

Smaller units weigh under 100 pounds and can be easily moved by two people.

Fields of Application



Kitchens

Restaurants, hotels.

Institutional and processing facilities



ecoGrease-a model sizes.

ecoGrease-a offers a full range of above ground oil water separators. The following models are available:

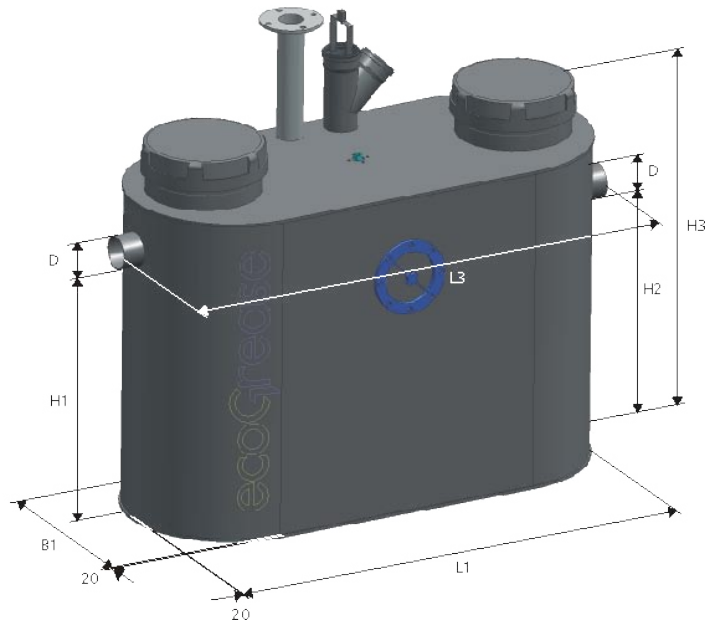

Flow rate		Volume Grit Trap		Grease Capacity		Total Volume		Dimensions												Weight					
								D		L1		L3		H1		H2		H3				B1		B2	
[l/s]	[gpm]	[l]	[gal]	[l]	[gal]	[l]	[gal]	[mm]	[in]	[mm]	[in]	[mm]	[in]	[mm]	[in]	[mm]	[in]	[mm]	[in]	[mm]	[in]	[mm]	[in]	[kg]	[lb]
2	32	200	53	121	32	620	164	110	4	1440	57	1640	65	880	35	810	32	1215	48	620	24	750	30	65	143
4	63	400	106	166	44	975	258	110	4	1750	69	1950	77	1010	40	940	37	1300	51	620	24	750	30	75	165
7	111	700	185	282	74	1937	512	160	6	2170	85	2370	93	1180	46	1110	44	1570	62	910	36	950	37	280	617
10	159	1000	264	401	106	2754	728	160	6	2995	118	3195	126	1180	46	1110	44	1570	62	910	36	950	37	320	705

Operation and Maintenance.

Installation:

The separator must be installed above grade and leveled on a solid surface. The chosen location for the system should be as close as possible to the source of waste stream to be treated. When choosing the location, make sure that the separator can easily be accessed for maintenance. Avoid any pipes or hydraulic structures that may contribute or increase the amount of mechanically emulsified oil, upstream to the separator. When the influent holding vessel requires it to be pumped, only positive displacement, diaphragm or screw type pump should be employed to avoid extreme mechanical emulsification of oil-laden wastewater. The system is designed for use inside a building. Avoid high temperature or exposure to sunlight. Ensure proper venting of the system.

Maintenance:

Remove sludge and grease from the system periodically. Since the maintenance intervals strongly depend on the specific application, check grease and solids level weekly during the first 60 days of operation.

Temperature range of operation: 5°C to 60°C (40 to 140°F)

Material: High grade polyethylene

ecoTECHNIC GmbH & Co KG

Tel: +43 (0) 7735 7320-0 Fax: -58

support@ecotechnic.at, www.ecotechnic.at

ecOTECHNIC
TECHNOLOGY THAT SEPARATES